

# PE

3042 Jaw Crusher



## The Affordable Alternative in New Crushing Equipment

### Standard Features

- Single wall main frame of stress relieved steel
- Open back for easy maintenance
- All working parts lubricated for moisture and dirt protection
- Reversible manganese jaw dies for maximum wear life
- Large, spherical, self-aligning roller bearings
- Isolated, close running annular/labyrinth seals protect bearings from dust and water
- Removable pitman/bearing assembly for maintenance ease
- Hydraulic shim adjustment
- Heavy duty, cast steel pitman with machined barrel
- Machined pitman face for full swing jaw die support
- Smooth running flywheels with compression ring fastening arrangement
- Pitman wear plate

### Optional Features

- Electric motor
- Drive sheave and bushing
- Heavy duty jaw dies (challenger style)



## The Affordable Alternative in New Crushing Equipment

### Specifications

Feed opening	30" × 42"
Discharge setting	3" to 6"
Maximum feed size	25"
Production range	100 to 250 TPH
Discharge setting	
3"	100 to 125 TPH
3-1/2"	125 to 150 TPH
4"	150 to 175 TPH
4-1/2"	175 to 200 TPH
5"	200 to 225 TPH
6"	225 to 250 TPH
Required horsepower	150 HP
Rotor speed	250 RPM

Weights (LBS)	
Crusher	63,900
Flywheel	4,300
Swing jaw die	3,200
Fixed jaw die	3,170
Standard part dimensions (inches)	
Fixed jaw length	66 1/8
Swing jaw length	74
Bearing information	
Pitman bearing No.	23176CA/W33
Frame bearing No.	23176CAK/W33

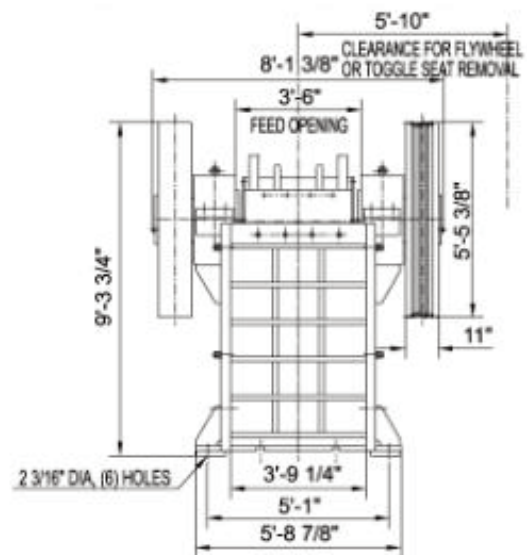
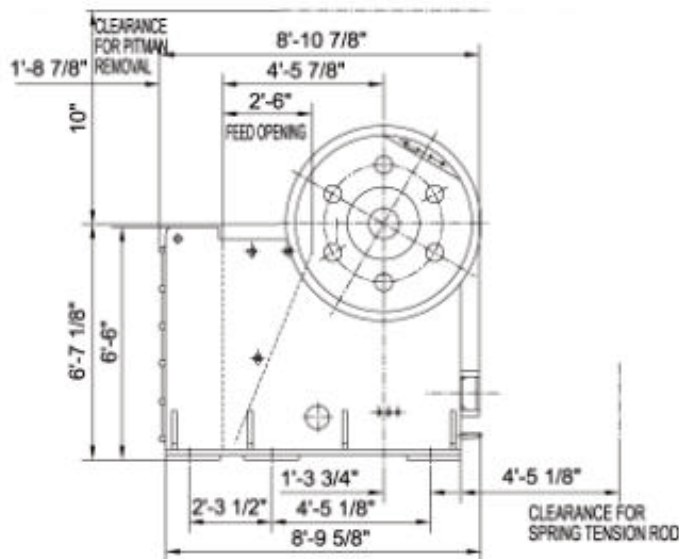

Note: Because of the nature of jaw crushers, it is not possible to produce a product all of which will pass a screen opening equivalent to the discharge setting. Oversize should be expected, and will fluctuate depending on the rock characteristics. For close settings, all undersize material should be screened off to increase the effectiveness of the jaw and to reduce wear on the jaw dies. Although the crusher may be configured to have a different discharge opening than indicated above, this crusher model is not designed to operate at other settings.